

1	GIALLO = MUTE OUT Connettere MUTE AUTORADIO
2	ARANCIO = SOTTOCHIAVE + 15 (USCITA)
3	ROSA = CAN BUS "H"
4	VIOLA = K-BUS NON CONNETTERE
5	VERDE = CAN BUS "L"
6	ROSSO = POSITIVO FISSO (Batteria)
7	GIALLO/NERO = MUTE IN Connettere al MUTE vivavoce
8	BLUEBOX PARROT
9	DISPLAY
10	MUTE BOX PARROT
11	USCITA ALTOPARLANTI
12	CONNETTERE AL VIVAVOCE
13	CONNETTERE AL VIVAVOCE

POSIZIONE CONNESSIONI CAN BUS E MUTE

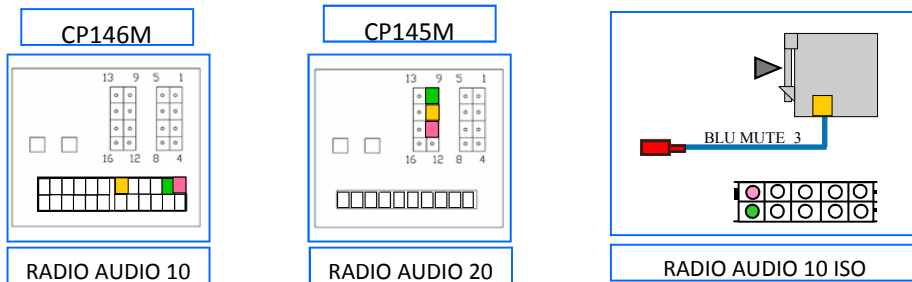

■ CAN BUS H
 ■ CAN BUS L
 ■ MUTE

SETTAGGIO SWITCHES

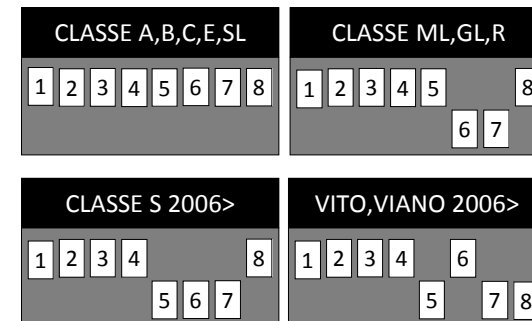

LE LINEE CAN BUS DI MERCEDES SONO INDIVIDUABILI SU TUTTO L'IMPIANTO DELL'AUTO E SONO DI COLORE **MARRONE e MARRONE/ROSSO**



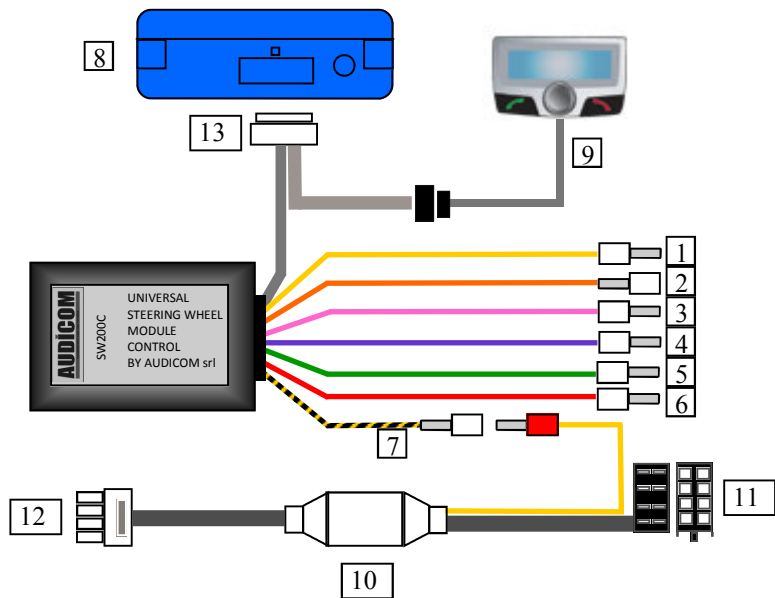

1	GIALLO = MUTE OUT Connettere MUTE AMPLIFICATORE	1
2	ARANCIO = SOTTOCHIAVE + 15 (USCITA)	
3	ROSA = CAN BUS "H"	3
4	VIOLA = K-BUS NON CONNETTERE	
5	VERDE = CAN BUS "L"	5
6	ROSSO = POSITIVO FISSO (Batteria)	
7	GIALLO/NERO = MUTE IN Connettere al MUTE vivavoce	
8	BLUEBOX PARROT	
9	DISPLAY	
10	MUTE BOX PARROT	
11	USCITA ALTOPARLANTI	
12	CONNETTERE AL VIVAVOCE	
13	CONNETTERE AL VIVAVOCE	

CP147

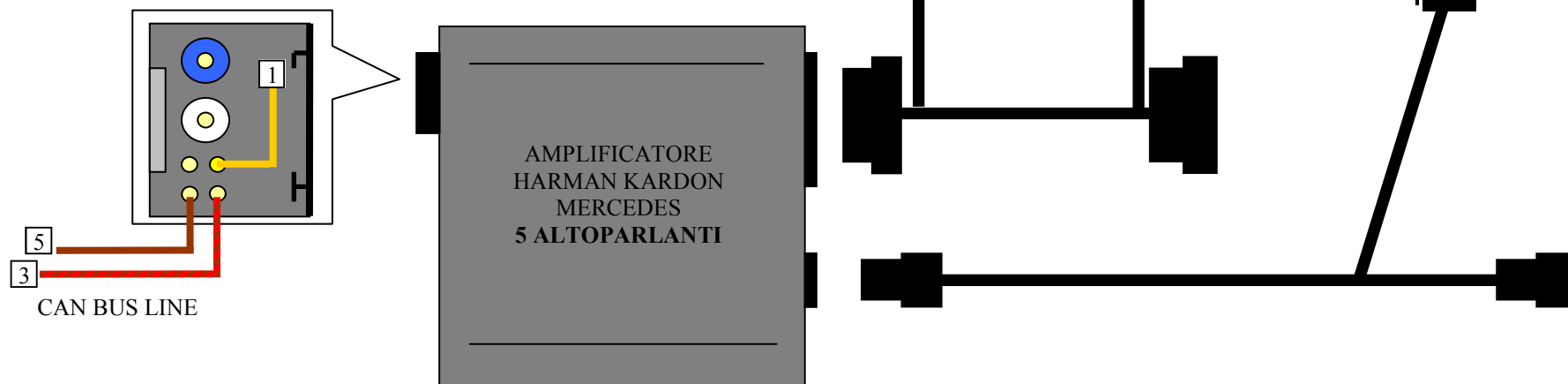

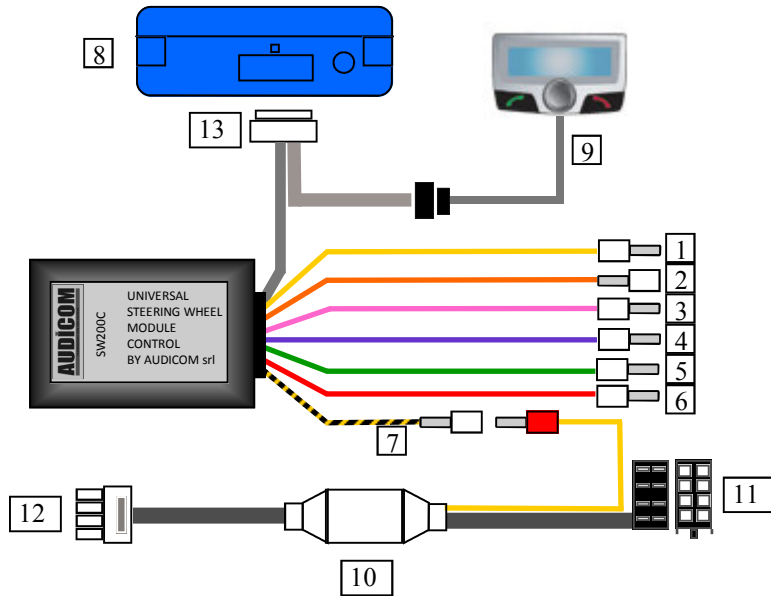

1	GIALLO = MUTE OUT Connettere MUTE AMPLIFICATORE	1
2	ARANCIO = SOTTOCHIAVE + 15 (USCITA)	
3	ROSA = CAN BUS "H"	3
4	VIOLA = K-BUS NON CONNETTERE	
5	VERDE = CAN BUS "L"	5
6	ROSSO = POSITIVO FISSO (Batteria)	
7	GIALLO/NERO = MUTE IN Connettere al MUTE DEL CP148	2
8	BLUEBOX PARROT	
9	DISPLAY	
10	MUTE BOX PARROT	
11	USCITA ALTOPARLANTI	
12	CONNETTERE AL VIVAVOCE	
13	CONNETTERE AL VIVAVOCE	

CP148

MERCEDES CLESSE E

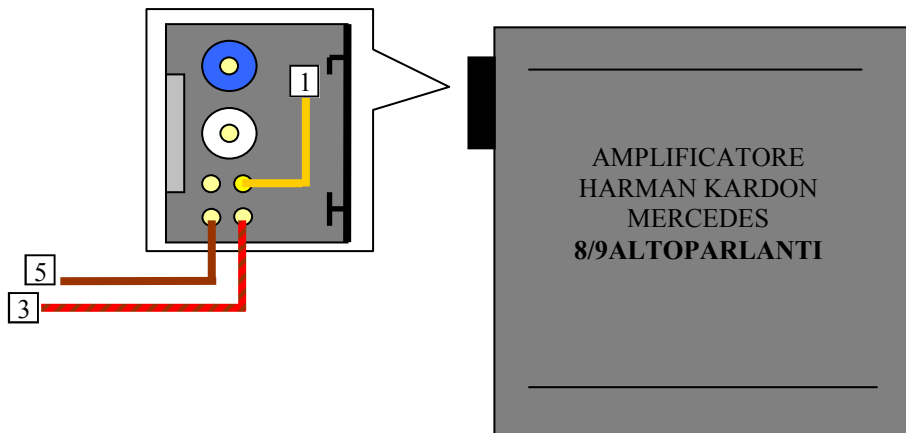
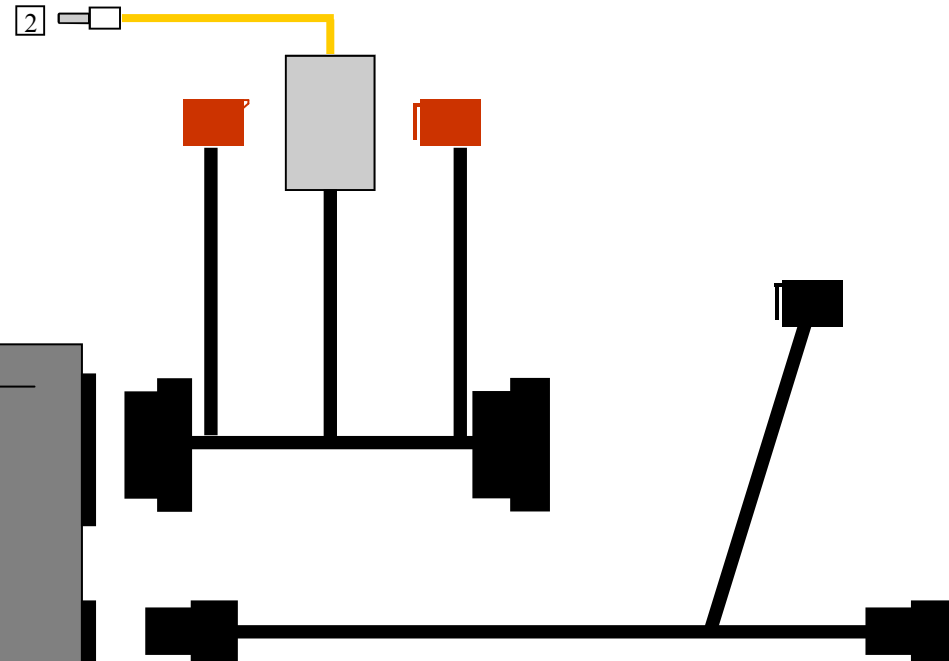

AMPLIFICATORE
HARMAN KARDON
MERCEDES
8/9ALTOPARLANTI

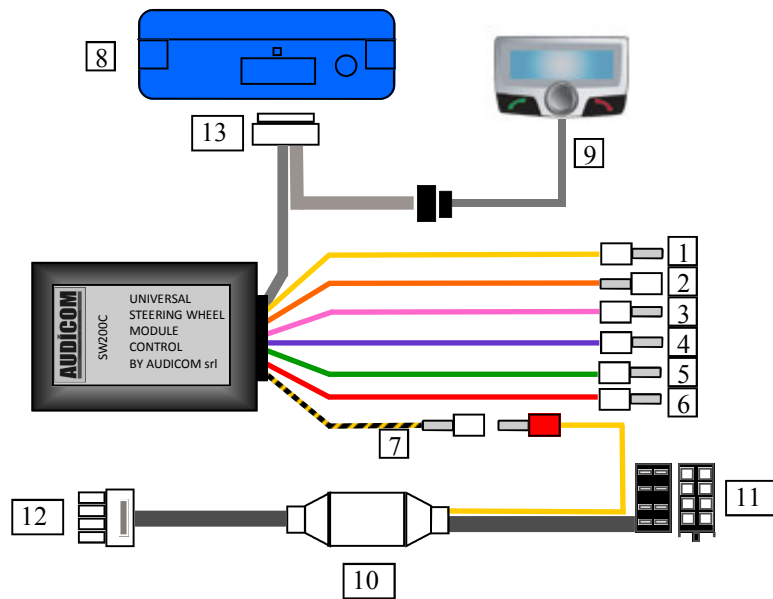

1	GIALLO = MUTE OUT Connettere MUTE AMPLIFICATORE	1
2	ARANCIO = SOTTOCHIAVE + 15 (USCITA)	2
3	ROSA = CAN BUS "H"	
4	VIOLA = K-BUS NON CONNETTERE	
5	VERDE = CAN BUS "L"	
6	ROSSO = POSITIVO FISSO (Batteria)	
7	GIALLO/NERO = MUTE IN Connettere al MUTE DEL VIVA VOCE	
8	BLUEBOX PARROT	
9	DISPLAY	
10	MUTE BOX PARROT	
11	USCITA ALTOPARLANTI	
12	CONNETTERE AL VIVA VOCE	
13	CONNETTERE AL VIVA VOCE	

CP149

MERCEDES ML,R,GL

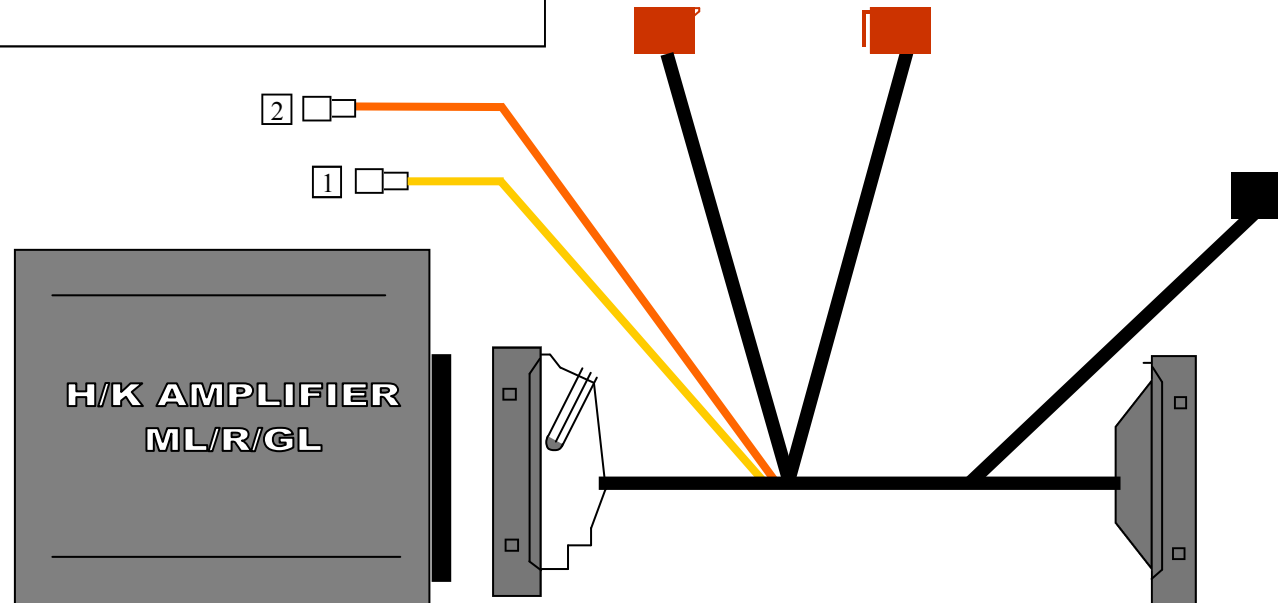

NOTA : L'AMPLIFICATORE E' POSIZIONATO SOTTO LA MOQUETTES SOTTO IL SEDILE GUIDATORE

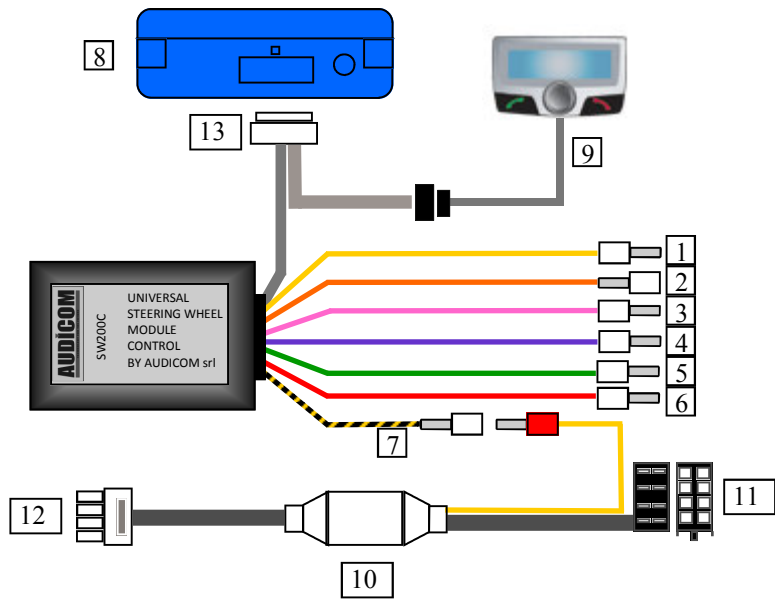

1	GIALLO = MUTE OUT Connettere MUTE BOX CP143	1
2	ARANCIO = SOTTOCHIAVE + 15 (USCITA)	2
3	ROSA = CAN BUS "H"	
4	VIOLA = K-BUS NON CONNETTERE	
5	VERDE = CAN BUS "L"	
6	ROSSO = POSITIVO FISSO (Batteria)	
7	GIALLO/NERO = MUTE IN Connettere al MUTE DEL CP148	
8	BLUEBOX PARROT	
9	DISPLAY	
10	MUTE BOX PARROT	
11	USCITA ALTOPARLANTI	
12	CONNETTERE AL VIVAVOCE	
13	CONNETTERE AL VIVAVOCE	

CP143

MERCEDES CLASSE C 2007>

